

# GREENWAY VISION

Warren County has become a leader in the protection of the remnants of the Morris Canal by promoting a greenway corridor and preserving the historic remains of the canal as an important part of the County's transportation history.



The vision is to have this greenway extend across Warren County with the canal as a link to recreational, cultural, and historic areas including state park trails, and municipal and county public open space. This greenway will extend between Phillipsburg and the historic Waterloo Village – a restored canal town.

In some places the towpath will become a recreational trail open to the public for non-motorized activities. In other places pocket parks will be established for the public's enjoyment. When completed, this greenway will be a living reminder of the County's transportation heritage while promoting the economic benefits of cultural and heritage tourism.

Warren County offers a wide range of recreational opportunities and its rural nature and scenic beauty are worthy of long-term preservation.



## THE MORRIS CANAL

Listed on the State and National Registers of Historic Places

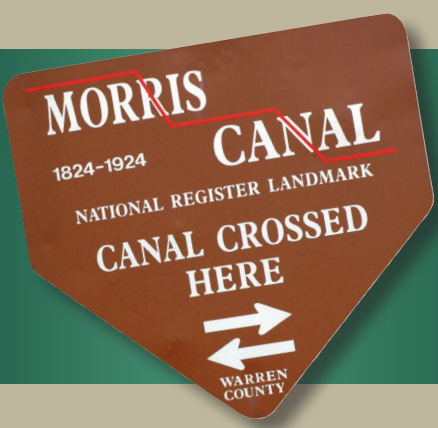

# MORRIS CANAL INCLINED PLANE 9 WEST

WARREN COUNTY, NEW JERSEY

### For Further Information Contact:

#### WARREN COUNTY PLANNING DEPARTMENT

County Administration Building  
165 County Road 519 South  
Belvidere, NJ 07823  
908-475-6532

#### WARREN COUNTY MORRIS CANAL COMMITTEE

c/o Warren County Planning Department

#### WARREN COUNTY BOARD OF RECREATION COMMISSIONERS

c/o Warren County Office of Land Preservation  
908-453-2650

#### PUBLIC INFORMATION AND TOURISM DEPARTMENT

908-475-6580  
800-554-8540

WEB SITES: [www.co.warren.nj.us](http://www.co.warren.nj.us)  
[www.morriscanal.org](http://www.morriscanal.org)  
[www.canalsocietynj.org](http://www.canalsocietynj.org)

### Prepared by:

#### WARREN COUNTY MORRIS CANAL COMMITTEE

Funding provided by  
Warren County Board of Chosen Freeholders

Historic Photos: Courtesy of James Lee

Design: MacGraphics

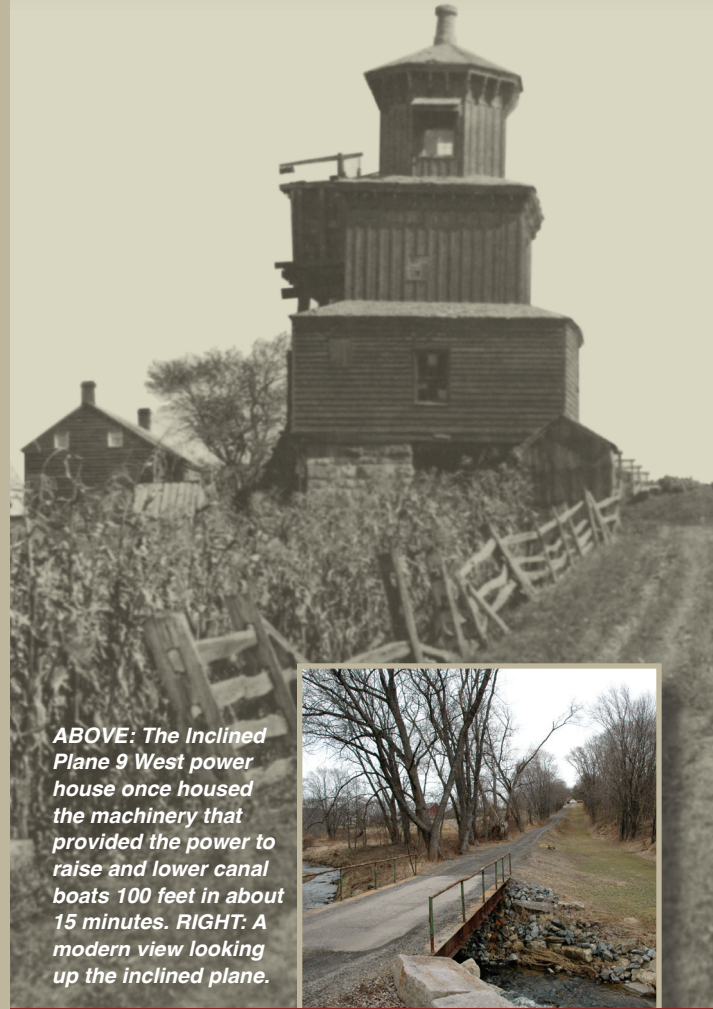

ABOVE: The Inclined Plane 9 West power house once housed the machinery that provided the power to raise and lower canal boats 100 feet in about 15 minutes. RIGHT: A modern view looking up the inclined plane.

A LINK TO OUR HISTORY  
A PATHWAY TO OUR FUTURE

# POWER HOUSE

Morris Canal Inclined Plane was a huge and powerful machine that could raise or lower a fully loaded canal boat one hundred feet in less than fifteen minutes. To provide the power, water was brought to the power house from the upper level of the canal in an overhead trough called the headrace flume. From the end of the flume the water was dropped 47 feet down a wood and iron penstock pipe to operate a reaction turbine, housed in a chamber below. The column of water in the penstock weighing many tons forced the rotor to turn like a huge lawn sprinkler. A shaft transmitted power from the turbine rotor to gearing that turned a cable drum in the power house above. The used water flowed out the turbine chamber down a tailrace tunnel and into the lower level of the canal to be used at the next inclined plane.

It took two men to operate the plane. The plane tender manned the controls and operated the machinery at the power house. The brakeman rode the cradle car, organized the loading and unloading of the boats and operated a brake when needed.

From his perch in the cupola atop the power house, the plane tender could see the brakeman's signals from either the top or the bottom of the plane. When a boat was secured in one of the cradle cars, the plane tender raised the tub valve at the end on the headrace flume dropping thousands of tons of water to turn the turbine below. A simple clutch engaged the cable drum in the appropriate direction to move a canal boat up or down the plane.

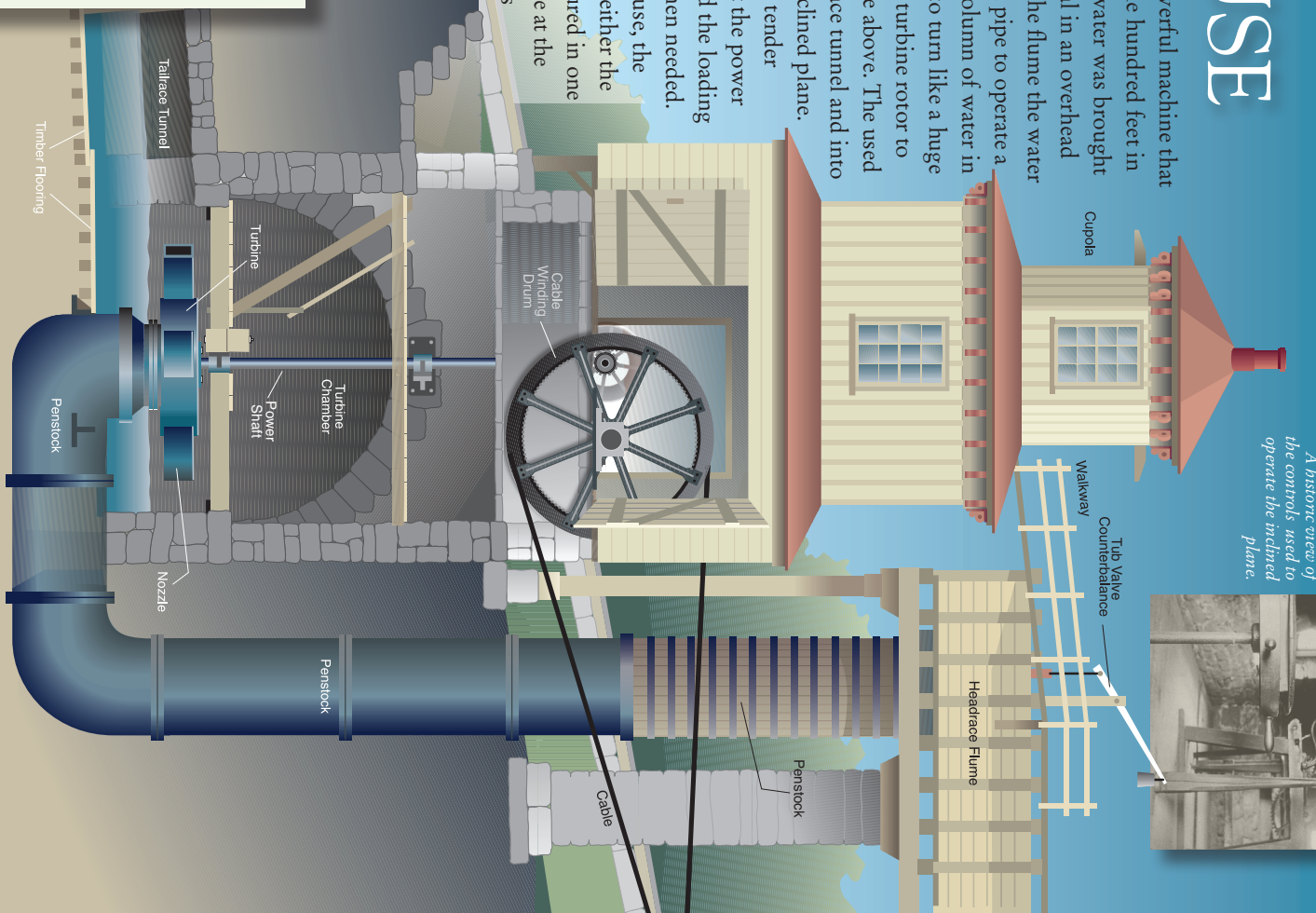
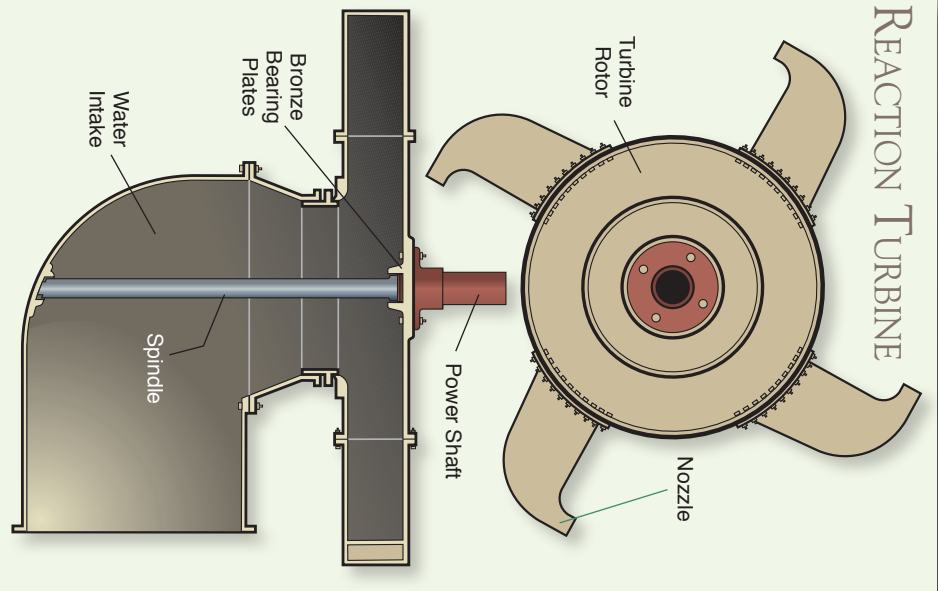

If the inclined plane was not in operation excess water could flow out of the headrace down a bypass flume and channel and into the lower level of the canal. This allowed water to bypass the turbine in the power house and assure the canal could maintain the proper water level.

The power house stood tall against the skyline with a third story cupola that gave the plane tender a view of both the top and the bottom of the plane. The headrace flume brought tons of water to turn the reaction turbine in the chamber below.

A historic view of the controls used to operate the inclined plane.



# THE INCLINED PLANE

To help the canal climb over the New Jersey Highlands on its way from Phillipsburg to Jersey City, the Morris Canal & Banking Company developed inclined planes to raise and lower its canal boats up to 100 feet at a time. Built in the 1830s and redesigned in the 1850s, these huge machines were up to 1,400 feet long and capable of moving boats loaded with 70 tons of cargo from one canal level to the next. The canal used 23 of these inclined planes and 23 lift locks to overcome an elevation change of almost 1,700 feet, an unbroken world record. After years of service, the canal was abandoned in 1923 and much of its infrastructure was dismantled. However, at Inclined Plane 9 West the plane tender's house, turbine chamber and tailrace tunnel are still in place making this site one of the best remaining examples of these engineering marvels.

## 1 The Power House

The stone foundation of the power house is still intact with its opening covered with iron bars. You can see the reaction turbine that once powered the plane still in place in the chamber below. Nearby are assembled pieces of the penstock and parts of the machinery. Across the driveway is the plane itself marked by a double row of sleeper stones. A modern reconstruction shows how the plane rails were supported on heavy wooden timbers that provided a flexible cushion between the rail and the sleeper stones.

## 2 The Tailrace

Downhill from the power house is the iron arch that frames the end of the tailrace tunnel. Here, used water from the turbine chamber and water from the bypass flume joined to flow down the tailrace channel and into the lower level of the canal at the bottom of the plane. When tours are being offered, it is possible to walk up the tailrace tunnel and into the turbine chamber. The

huge reaction turbine that once powered the plane almost completely fills the room. When the plane tender opened the tub valve above, the pressure of thousands of tons of water would send the head of the turbine spinning at about 60 revolutions per minute. Water from the turbine's four nozzles would fill the chamber and send a river surging down the tailrace tunnel.

## 3 The Plane Summit

At the top of the plane the summit acted as a dam to contain the water in the upper level of the canal and divert it into the headrace flume. A double set of tracks came up the plane, over the summit and back down into the water. The 90-foot-long canal boats and cradle cars were built in two hinged sections that could flex as they crossed the summit of the plane. Plane 9 West's double set of tracks and two cradle cars, allowed boats to go up and down the plane at the same time.

## THE WATER

The water to power the inclined plane was brought to the powerhouse from the upper level of the canal in a headrace flume supported on a wooden trestle and stone piers. At the power house the water was dropped 47 feet to turn a reaction turbine located in a chamber below. Used water exited the turbine chamber through a tailrace tunnel and flows into the lower canal level to be used to power the next inclined plane. When the inclined plane was not in operation, water was routed through a bypass flume and channeled directly to the lower level of the canal.

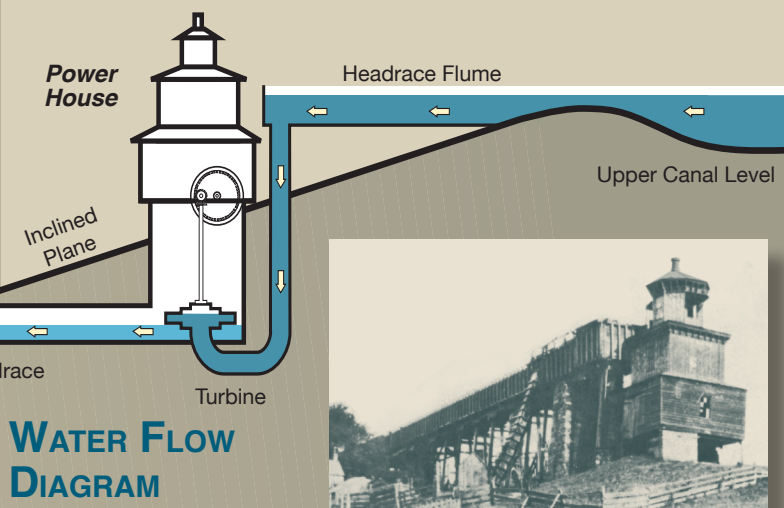

The headrace flume, measuring eight feet wide by five feet deep, brought water from the upper level of the canal to the power house.



The Plane 9 West power house is seen above, while below water flows from the bypass trough on the left and the tailrace tunnel on the right.

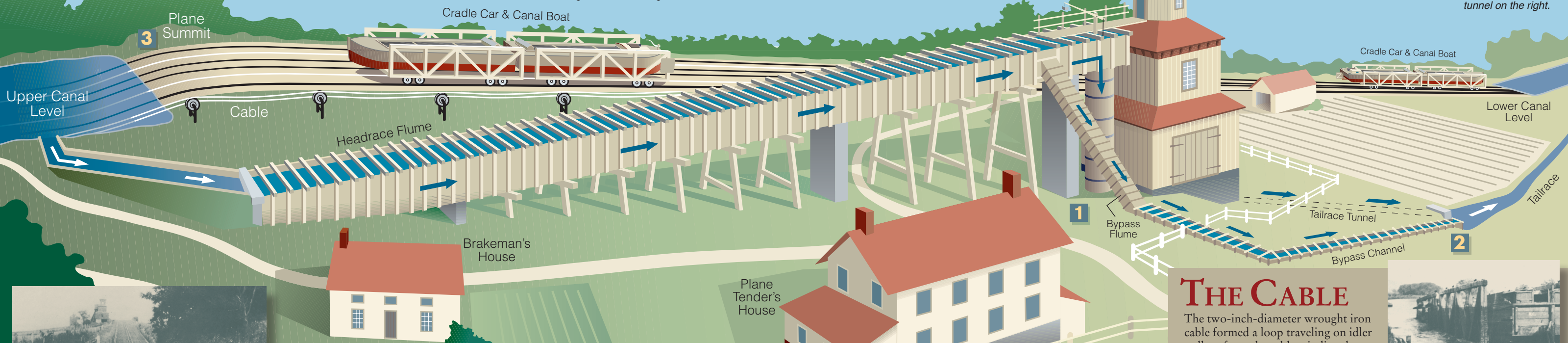

## THE CRADLE CARS

Canal boats were transported up and down the inclined plane on wheeled cradle cars riding on iron rails. To facilitate loading and unloading the boats the rails extended down into the bottom of the canal at both ends of the plane. The cradle cars rolled down into the water and the boats were floated on. A brakeman supervised the loading, rode the cradle car up and down the plane, and applied a brake to keep the car under control. Both the boats and cradles were built in two sections so that they could flex as they crossed the summit of the plane.

A cradle car and canal boat on its way up the inclined plane.

An empty cradle car sits in the water at the bottom of the inclined plane.

## THE CABLE

The two-inch-diameter wrought iron cable formed a loop traveling on idler pulleys from the cable winding drum in the power house to sheave wheels located under water in the upper and lower levels of the canal. As the cable drum turned it pulled the cable and moved the cradle cars loaded with canal boats up and down the plane.

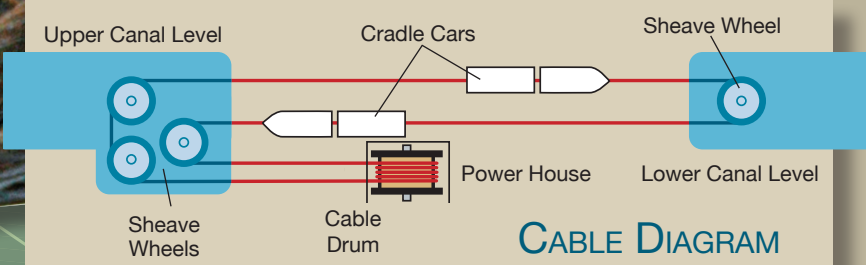

CABLE DIAGRAM

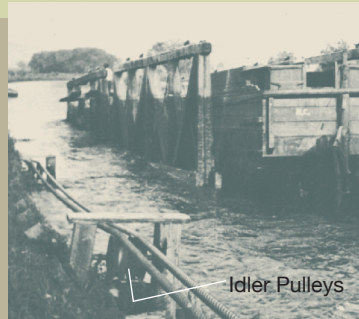

Idler Pulleys

